



Hurst/Olds Club of America established 1983

Fed. Tax ID 90-0639846
A non-profit 501 (c) (7) organization

1984 Hurst/Olds Spotter Tips

The Hurst/Olds is a limited production car built by Oldsmobile and Hurst Performance in 10 select years from 1968 to 1988. In 1984, the Hurst/Olds came with only one exterior color. All H/O's were silver with a wide black band on the lower edge, accented with a red stripe. They were built on the Cutlass Calais body with a 180hp 307 engine. 3500 H/O's were built. All interiors were Dark Maple in either cloth or vinyl and air conditioning was mandatory on all of these cars.

- Fisher Body tag is located under the hood and on the cowl above the power brake booster area. It will decode as follows:

E	Year of car 1984
O2D	Build date code-Example is February (02), 4 th week (D)
3	Oldsmobile Division
GR	Cutlass Calais
47	2-door Coupe
M	Built in Michigan, Lansing Plant
-----	BODY Fisher Body sequential #
17L	Silver paint, lower body
17U	Silver paint, upper body
Lacquer	Type of paint, lacquer
77C	Interior: Dark Maple Cloth (77R-Dark Maple Vinyl)
AR9	Reclining Bucket Seats
CC1	Removable Roof Panels *NOTE- There may be several additional codes in this area for additional options
Y78	Calais option
W40	Hurst/Olds Option



NOTE- Letter/number combination in lower left corner is unknown and different on every tag

- The VIN is located on the dash and in front of the driver. It is viewed from outside, through the windshield. It will have the following: **1**- USA; **G**-General Motors; **3**-Oldsmobile Division; **A**- Non-passive manual seat belts; **K**- Cutlass Calais Body; **47** – 2-door Coupe; **9**- 307 Hurst Option; **1**-check digit used to verify VIN has been correctly recorded; **E**- 1984; **M**- Lansing, Michigan assembly plant; ----- Six digit sequential number from Oldsmobile.



- All engines were a 307cid with four-barrel engine, casting # 3161-5A – and painted GM Corporate black. Federal regulations required that all auto assembly plants stamp the VIN from the car onto the engine that is being installed at the assembly plant. On an Oldsmobile V8 engine the stamping location is as indicated in the diagram. The code will be as follows:

3	Indicates Oldsmobile Division
E	Model year 1984
M	Built in Lansing
-----	Last 6 numbers of the VIN

The stamping is on the small smooth pad on the block and is seen from the driver's side. Some of the stamped digits are angled rather than a block style. It is below the cylinder head, behind the power steering pump and difficult to see.

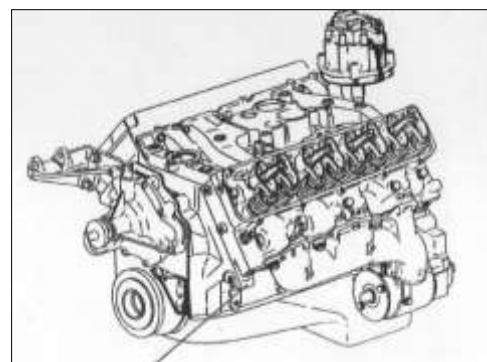

- Cylinder heads were cast with a 5A on them. The casting letter is located on the front of the left cylinder head and rear of right cylinder head.

